

- 3** REMOVE THE MIDDLE LINING FROM THE UNDERSIDE OF THE FLEXATILE.

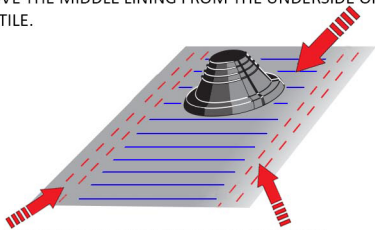

BUTYL ADHESIVE STRIP ON THE UNDERSIDE OF FLASHING

- 2** CUT THE RUBBER CONE AT LEAST 15mm SMALLER THAN PIPE O.D. WITH A SHARP KNIFE OR SCISSORS

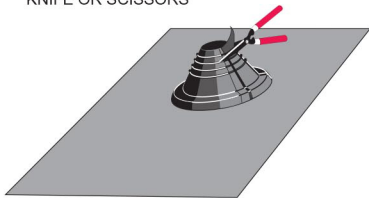

- 1** ENSURE TILES ARE CLEANED BEFORE INSTALLING THE FLEXATILE FLASHING TO ENSURE THE BUTYL ADHESIVE STRIPS CAN HAVE MAXIMUM EFFECT WHEN BONDED TO THE TILES

- 4** LUBRICATE PIPE WITH WATER AND SLIDE THE FLASHING DOWN THE PIPE

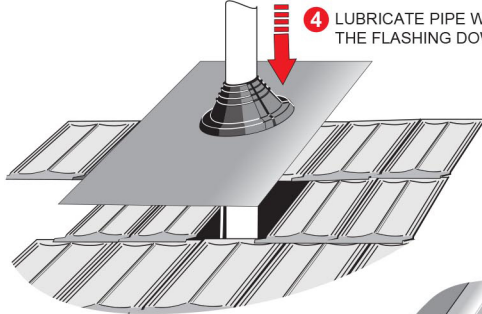

- 5** FORM AN ANTI-CAPILLARY FOLD AT TOP OF BASE SHEET



- 6** REMOVE THE PROTECTIVE BACKING FROM THE UNDERSIDE OF FLASHING, THAT IS COVERING THE BUTYL ADHESIVE STRIPS

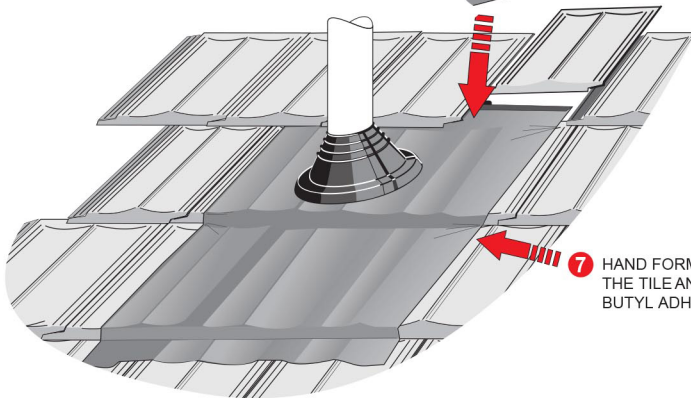

- 7** HAND FORM THE BASE ALL AROUND THE TILE AND APPLY PRESSURE TO THE BUTYL ADHESIVE SIDE STRIP